



WATER COOLERS

INSTALLATION/MAINTENANCE INSTRUCTIONS

A172.8FGVR Series Barrier Free, 14 Gage Stainless Steel, Enhanced Vandal Resistance, Bi-Level, Wall Mounted Water Cooler



TECHNICAL ASSISTANCE TOLL FREE TELEPHONE NUMBER:
1.800.591.9360

Technical Assistance Fax: 1.626.855.4894

NOTES TO INSTALLER:

1. Please leave this documentation with the owner of the fixture when finished.
2. Please read this entire booklet before beginning the installation.
3. Check your installation for compliance with plumbing, electrical and other applicable codes.

LIMITED WARRANTY - UNITED STATES & CANADA

Murdock warrants that every cooler, bottle filling station, packaged water chiller, fountain and accessory to be free from defects in material and workmanship under normal use for one (1) year from date of install or eighteen (18) months after the date of shipment from the factory, whichever comes first.

Murdock warrants the compressor and hermetically sealed refrigeration system, including cooling coil assembly when part of the hermetically sealed refrigeration system, to be free from defects in material and workmanship under normal use for an additional four (4) years from the end of the one (1) year period described above.

This warranty does not cover installation or labor charges and does not apply to materials, which have been damaged by other causes such as mishandling or improper care or abnormal use. The repair or replacement of the defective materials shall constitute the sole remedy of the Buyer and the sole remedy of Murdock under this warranty. Murdock shall not be liable under any circumstances for incidental, consequential or direct charges caused by defects in the materials, or any delay in the repair or replacement thereof. This warranty is in lieu of all other warranties expressed or implied. Product maintenance instructions are issued with each unit and disregard or non-compliance with these instructions will constitute an abnormal use condition and void the warranty. Stainless steel must be protected on job site during construction and must be properly maintained after the water has been introduced into the water cooler or drinking fountain, or Murdock's limited warranty is void.

LIMITED EXPORT WARRANTY - One year on parts only.

Murdock assumes no responsibility for use of void or suspended data. © Copyright Murdock, City of Industry, CA Member of Morris Group International. Please visit www.murdockmfg.com for most current specifications.

COMPLIES WITH
STANDARDS



Test rating conditions are compliant with ARI 1010.



Member of
MORRIS GROUP
INTERNATIONAL

MURDOCK
15125 Proctor Ave.
City of Industry, CA
91746 U.S.A.
Phone 800-591-9360
626-336-4561
Fax 626-855-4894

www.murdockmfg.com

7020-928-001

Date: 07/18/18



WATER COOLERS

INSTALLATION/MAINTENANCE INSTRUCTIONS

IMPORTANT

This fixture is intended to dispense water that has been lowered in temperature, but otherwise remains unchanged by the materials in the water cooler. It is common for electrical equipment to be grounded to water lines either within a structure or away from it. Every attempt should be made to prevent this kind of grounding from generating electrical feedback into the water cooler creating electrolysis. Electrolysis will cause a metallic taste or cause water metal content to increase.

NOTICE

A dielectric coupling must be used to connect the water cooler to the water supply. A nonmetallic coupler is furnished with this water cooler to meet this requirement.

ROUGHING-IN AND DIMENSIONAL DRAWING

Prior to roughing consult with local, state, and federal codes for proper mounting height.

A172408FGVR Wall Mounted Drinking Fountain

- A. 3/8" NCT SUPPLY INLET
- B. WASTE OUTLET FOR 1-1/4" P-TRAP BY OTHERS
- C. ELECTRICAL SERVICE ROUGH
- D. Ø1/2" HANGER BRACKET PUNCHING, 3 PLACES FOR ANCHORING HARDWARE BY OTHERS
- E. Ø5/16" PUNCHING, 2 PLACES FOR ANCHORING HARDWARE BY OTHERS

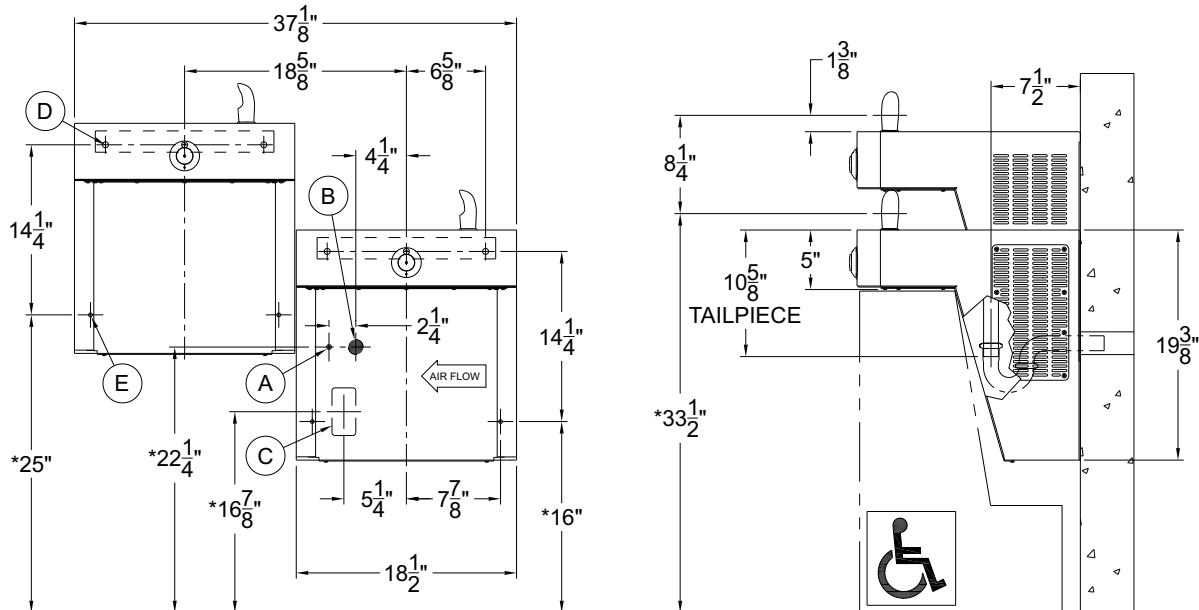

GENERAL NOTES:

1. ALL DIMENSIONS ARE IN INCHES [MM]
2. ALLOW 4 INCHES [102 MM] MINIMUM CLEARANCE PER SIDE FOR VENTILATION
- *3. DIMENSIONS SHOWN ARE FOR RECOMMENDED ADULT HEIGHT. ADJUST VERTICAL DIMENSIONS AS NECESSARY TO COMPLY WITH FEDERAL, STATE, & LOCAL CODES
4. STOP VALVE, P-TRAP, & ELECTRICAL OUTLET NOT SUPPLIED
5. IMPORTANT: COOLERS MUST BE ATTACHED TO WALL WITH APPROPRIATE WALL ANCHOR SCREWS

NOTES: Dimensions indicated * are for ADA frontal approach installation. Adjust vertical dimension * as required to comply with federal, state, and local codes. For Child ADA compliant parallel approach, decrease spout height to 30" maximum above finished floor. Provide clear floor space as required.



WATER COOLERS

INSTALLATION/MAINTENANCE INSTRUCTIONS

A172408FGVR Wall Mounted Drinking Fountain- Reverse Bi-Level

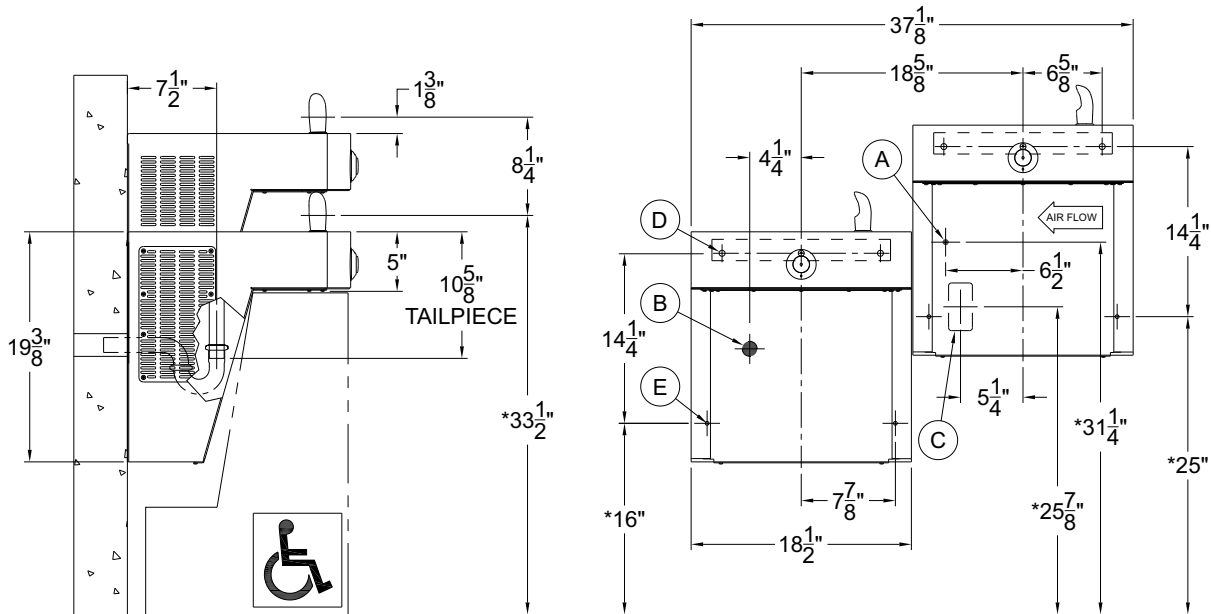

PRIOR TO INSTALLATION:

Important: some options may slightly alter installation. To ensure proper installation review the manual thoroughly and verify rough-ins before beginning work. File this manual with the owner or maintenance personnel upon completion of installation.

- Fixture mounting requirements: industry standard wall construction, adequate to support the fixture and installer provided wall anchors sufficient to secure the fixture.
- Receptacle(s) must be wired to a GFCI protected circuit. Fixture must be earth grounded per NEC (National Electric Code).
- Inspect fixture and all parts from damages and all parts are bolted on.

IMPORTANT:

1. Waste P-Trap, Water Supply Service Angle Stop Valve and 2" x 4" Electrical Plug-In Receptacle to be supplied by others in accordance with local codes. A metallic p-trap (by others) must be used for the drain connection.
2. Provide 4" minimum clear space on fixture sides to allow for proper ventilation through cabinet louvers.
3. Water supply is 3/8" Outer Diameter copper tube. Waste is 1-1/4" Outer Diameter.
4. Completely flush supply lines of all foreign debris before connecting to fixture. Water cooler is designed to not cause problems with taste, odor, color, or sediment. Optional water filter (Wf1) is available should any of these problems arise from the water supply.
5. Do NOT solder tubes inserted into the coupler as damage to the o-ring may result.
6. All burrs must be removed from outside of cut tubes before inserting into coupler or other components.
7. Power supply must be identical in voltage, cycle and phase to that specified on the cooler data plate. Electrical outlet and furnished power cord with plug must be used to supply power to fixture. Do NOT wire compressor directly to the power supply.



WATER COOLERS INSTALLATION/MAINTENANCE INSTRUCTIONS

8. This unit must be grounded per the requirements of applicable electrical codes.
9. Warranty is voided if installation is not made following current Acorn Engineering installation instructions and if components are assembled to the fixture that is not approved by Acorn Engineering.
10. Fixture operates within water pressure range of 20 to 105 psig. Acorn Engineering will not warranty fixtures damaged when connected to supply lines with flow pressure lower than 20 psig or higher than 105 psig. A pressure regulator must be furnished by others on supply line if inlet pressure is greater than 105 psig.
11. Due to cold waste water, Acorn Engineering recommends that p-trap supplied by installer be insulated to prevent excessive condensation.
12. Per UPC 609.10- *All building water supply systems in which quick acting valves are installed shall be provided with devices to absorb the hammer caused by high pressure resulting from the quick closing of the valve. These pressure-absorbing devices shall be approved mechanical devices. Water pressure-absorbing devices will be installed as close as possible to the quick closing valve.*

INSTALLATION:

1. Mount hanger bracket to wall horizontally level as shown in Roughing-In and Dimensional Drawing. **Note:** Adjust height of bracket if bubbler outlet height is required to vary from that shown. Hanger Bracket **MUST** be securely anchored to wall with fasteners sufficient to support 3 times weight of cooler. If wall can not provide adequate support, order and install optional fixture support carrier.
2. Remove the bottom cover from the water cooler and set aside in a safe place. Save the screws in a secure location for re-use in later stages of installation.
3. Hang the water cooler on the hanger bracket, ensuring the bracket tabs engage **AND** seat in the slots in the back of the water cooler. Verify water cooler is level, left to right **AND** front to back from bottom of unit. **NOTE:** The bubbler stream may be adversely affected if unit is not square and level. Bottom of unit and louvers should be used as reference to verify unit is square and plumb.
4. Anchor water cooler to wall at other mounting points in base. Shim lower rear mounting points to level unit if necessary.
5. Thoroughly flush the 3/8" O.D. supply line and then connect water cooler to water supply angle stop valve (by others) with supplied 3/8" O.D. copper tube.
6. Make up 1-1/4" O.D. p-trap (by others) waste connection.

START UP:

1. Before connecting power supply and assembling bottom cover to water cooler, but after thoroughly flushing the supply line and connecting it to the fixture, turn on building water supply and check all connections for leak.
2. Air within the water cooler system or the structure supply piping will cause an irregular bubbler outlet stream until purged out by incoming water. Covering the bubbler with a clean cup (or similar object) is recommended when first activating water cooler to prevent excessive splashing. Depress the pushbutton until steady water stream is achieved.
3. If water flow requires adjustment, insert a slotted narrow blade screwdriver through the hole centered on the pushbutton to the flow regulator. Turning clockwise will increase flow and turning counterclockwise will decrease flow.
4. Recheck all water and drain connections with water flowing through system.



WATER COOLERS INSTALLATION/MAINTENANCE INSTRUCTIONS

5. With power still NOT connected, carefully manually rotate cooling fan to insure proper clearance and free fan action.
6. Plug water cooler in to electrical outlet and make sure unit begins to function.
7. Assemble bottom cover to water cooler with screws furnished.

TROUBLE SHOOTING:

IMPORTANT: BEFORE MAKING ANY OF THE REPAIRS LISTED, MAKE SURE THE WATER COOLER IS DISCONNECTED FROM THE ELECTRICAL SUPPLY AND THE WATER SUPPLY VALVE IS SHUT OFF.

IMPORTANT : ASSUREZ-VOUS QUE LA FONTAINE D'EAU POTABLE RÉFRIGÉRÉE SOIT DÉBRANCHÉE DE LA PRISE DE COURANT MURALE ET QUE LE ROBINET D'ALIMENTATION D'EAU SOIT FERMÉ AVANT D'EFFECTUER LES RÉPARATIONS NÉCESSAIRES.

1. Adjustments:

- a. Cartridge – The water flow can be adjusted using a slotted narrow blade screwdriver and turning clockwise to increase flow and counterclockwise to decrease flow.
- b. Cold Water Thermostat – The water temperature can be adjusted using a slotted screwdriver and turning clockwise to make colder and counterclockwise to make warmer.
- c. Bubbler Stream – Bubbler can be rotated slightly to direct the stream backwards or forwards. Adjust the stream to minimize splashing. Splashing may occur from bubbler stream if the unit is not level. Shim lower mounting points, if necessary, to level cooler.

2. Compressor Does Not Run

- a. Check the electrical receptacle for power and correct voltage. The incoming voltage must be within 10% of the rated voltage on the serial nameplate.
- b. The cold thermostat is accessible by removing the bottom access cover. If the cold thermostat capillary bulb loses its charge or becomes kinked it will fail in the open position causing a disruption of power to the compressor. Unplug the water cooler and using an ohm meter check for continuity across the two electrical terminals on the thermostat. Install a new thermostat if there is no continuity.
- c. Check for loose wires within the compressor box. The incoming power leads must be connected to the overload and relay.
- d. If all components check positive for continuity then test the wiring harness plug for continuity to see if there is a broken wire within the wiring harness insulation.

3. Compressor Runs – Water Is Warm

- a. The most common cause for a water cooler to run without producing cold water is a loss of refrigerant. The water cooler must be taken to a certified refrigerant technician for repairs.
- b. Make sure the condenser fan motor is operative. The fan blade must turn freely to help remove the heat of compression.
- c. An incorrect refrigerant charge, restriction or defective compressor (not pumping) will also cause the compressor to run without producing cold water. All these signs indicate a problem within the refrigeration system and the water cooler must be checked by an authorized service company.

4. Compressor Cycling On Overload Protector

- a. A dirty condenser or a blocked fan will cause a high head pressure and frequent cycling of the overload protector.
- b. Check the incoming voltage to make sure it is within 10% of the serial nameplate rating.



WATER COOLERS INSTALLATION/MAINTENANCE INSTRUCTIONS

- c. A restriction or moisture in the system will also cause intermittent cycling. A certified refrigeration mechanic should be contacted in this situation.
 - d. Change the overload or relay if defective.
5. Noisy Operation
- a. Check to make sure the fan blade is rotating freely.
 - b. Make sure the water cooler is correctly mounted to the wall. Absence of the two lower mounting bolts may cause excess noise and vibration.
 - c. Check the compressor mounting to make sure the pins and clips are not rattling. If the compressor appears to be noisy internally, it must be replaced.
6. Restricted Or No Water Flow
- a. Ensure water supply service stop valve is fully open.
 - b. Verify minimum 20 psig supply line flow pressure.
 - c. Check for twists or kinks in bubbler tubing.
 - d. Check the water inlet strainer. Sediment from the main supply can get trapped in the screen along with installation materials such as pipe dope and flux. The screen should be cleaned and checked on a regular basis and replace if needed.
NOTE: STRAINER SCREEN MUST BE IN PLACE FOR WATER TO FLOW.
 - e. The cartridge valve located in the water control assembly or bubbler can also become clogged with foreign material. The cartridge valve can only be replaced and not repaired.
 - f. Check flow adjustment. See start up note #3.
 - g. The water cooler may also develop a freezing condition in which the water will become frozen inside the evaporator coil. This indicates a refrigeration problem or thermostat failure in which case the water cooler needs to be checked by a qualified technician.
7. Water Drip Or Will Not Shut Off:
- a. Remove Pushbutton. Adjust flow regulator to the highest setting using a flat head screwdriver and turning clockwise. Check if water drip continues, if it is no longer dripping turn screwdriver counter-clockwise until you have desired flow rate. Assure that retaining nut is tighten to valve assembly, 25 in-lb torque is required. If issue still continues after adjusting flow and tightening retainer nut, replacement of the flow regulator cartridge will be required in the center or two holes in convolution of the water diaphragm. Remove and clean.

CLEANING & MAINTENANCE GUIDE:

1. Motors have lifetime lubrication and do not require scheduled maintenance.
2. Excess dirt or poor ventilation will cause the compressor overload protector to turn the compressor off and it will cycle on and off with no cold water coming out of bubbler. Periodically clean with vacuum cleaner, air hose or brush the condenser fins and cabinet ventilation louvers. In environments where dirt and dust is more prevalent, clean more frequently.
3. Periodically remove access panels and clean out in-line strainer.
4. Do NOT use harsh chemicals, abrasive or petroleum based cleaners. Use of these will void the Acorn warranty.
5. Exterior panels can be cleaned using mild household detergents or warm, soapy water. Extra care must be used cleaning chrome plated items and mirror finished stainless steel. They can scratch easily and should only be cleaned using a clean, soft cloth and mild soap with water or a mild glass cleaner.



WATER COOLERS

INSTALLATION/MAINTENANCE INSTRUCTIONS

CARTRIDGE REPLACEMENT/ STRAINER MAINTENANCE

Note: Use the -VR maintenance tool to perform the following:

1. Strainer plug ③ **must** be removed before cartridge replacement and strainer maintenance (no need to turn the water off at the angle stop). Some residual water will drain during plug removal.
2. Clean strainer ④ as needed using clean water.
3. Cartridge replacement - Rotate and remove -VR pushbutton escutcheon ⑥ to release pushbutton ⑦ and springs ⑨⑩ to access cartridge.
4. Remove cartridge retaining nut ⑪ . Remove and replace cartridge ②. When replacing cartridge be sure to align the inlet and outlet ports on the cartridge with the ports in the valve body.
5. Install item ⑪ using maintenance tool ⑤ (Be careful not to over tighten)
6. Install button assembly items ⑥⑦⑧⑨⑩ using maintenance tool ⑤. Insure springs are fully seated onto button.
7. Reinstall strainer ④ and plug ③ using maintenance tool ⑤.

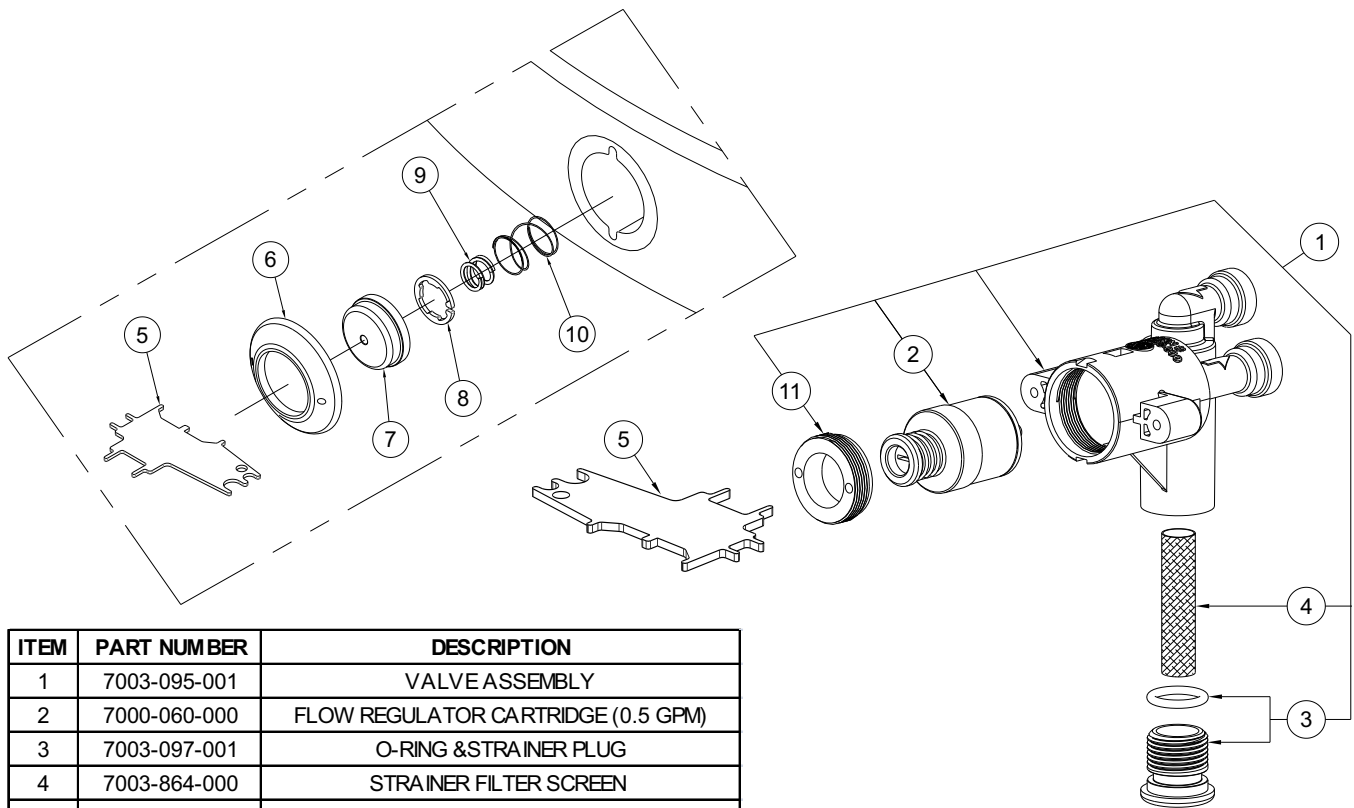

ITEM	PART NUMBER	DESCRIPTION
1	7003-095-001	VALVE ASSEMBLY
2	7000-060-000	FLOW REGULATOR CARTRIDGE (0.5 GPM)
3	7003-097-001	O-RING & STRAINER PLUG
4	7003-864-000	STRAINER FILTER SCREEN
5	7003-194-199	(-VR) MAINTENANCE TOOL
6	7003-197-199	(-VR) PUSHBUTTON ESCUTCHEON, CHROME
7	7003-196-199	(-VR) PUSHBUTTON, CHROME
8	7003-192-199	(-VR) PUSHBUTTON SPRING SPACER
9	7003-195-000	(-VR) PUSHBUTTON OVERTRAVEL SPRING
10	7003-193-000	(-VR) PUSHBUTTON RETURN SPRING
11	7000-052-000	RETAINING NUT

**NOTE: STRAINER FILTER SCREEN
MUST BE IN PLACE FOR
WATER TO FLOW.**



DRINKING FOUNTAINS

INSTALLATION/MAINTENANCE INSTRUCTIONS

OPTIONAL -WF1 WATER FILTER

See the following page for models with -WF1 Water Filter (A172.8-FG-VR-WF1)

ITEM	PART NUMBER	DESCRIPTION
1	7012-311-000	WF1 Filter 1500 Gal
2	1895-709-000	Elbow , Push in, 1/4" O.D. x 1/4" Stem
3	2169-000-000	1/4" O.D. LLDPE Tubing, Blue
4	7012-055-000	Foam Pipe Insulation
5	7003-670-001	Filter Assembly, FG

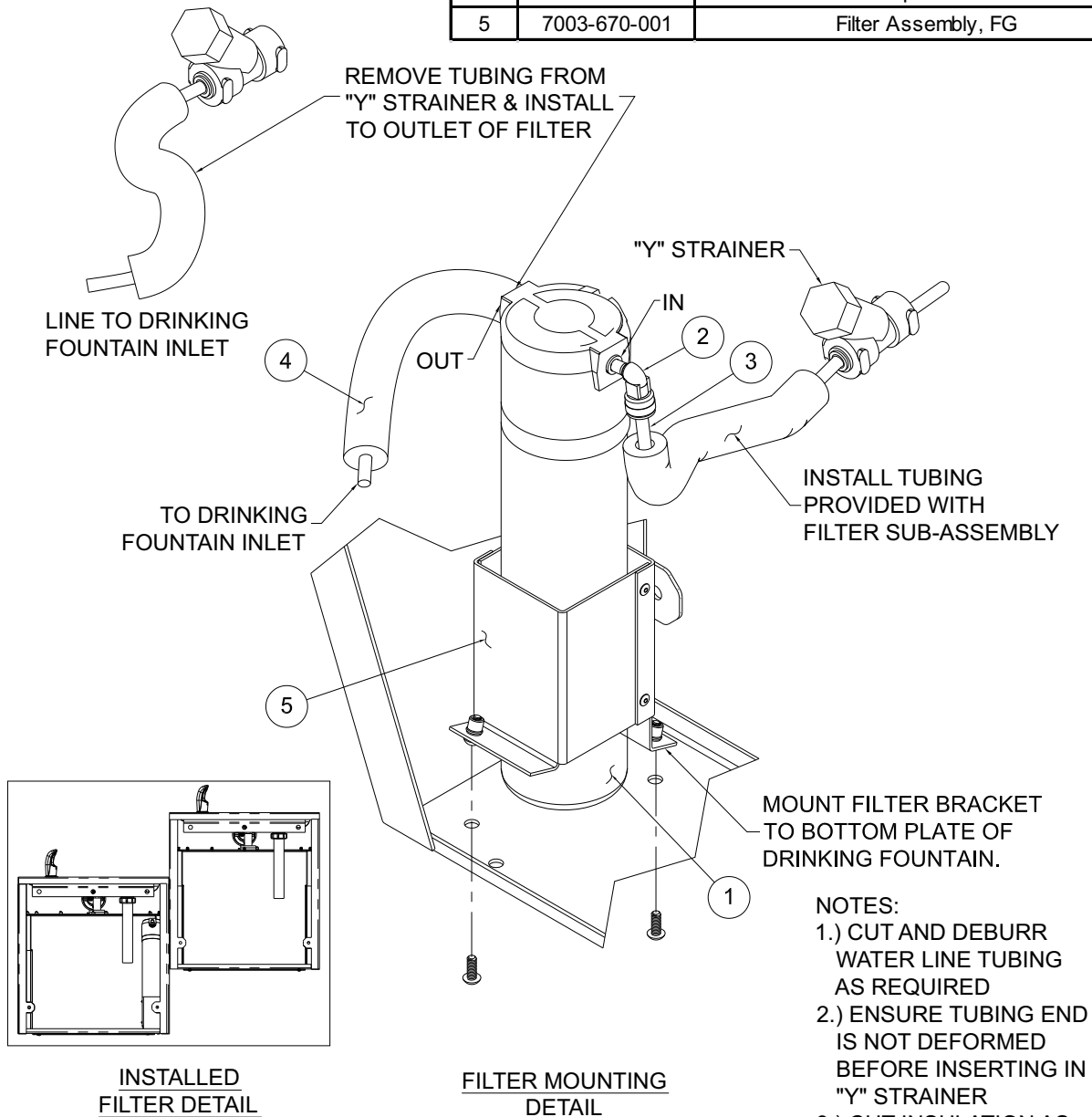

- NOTES:**
- 1.) CUT AND DEBURR WATER LINE TUBING AS REQUIRED
 - 2.) ENSURE TUBING END IS NOT DEFORMED BEFORE INSERTING IN "Y" STRAINER
 - 3.) CUT INSULATION AS REQUIRED TO COVER WATER TUBING



DRINKING FOUNTAINS

INSTALLATION/MAINTENANCE INSTRUCTIONS

OPTIONAL -WF1 WATER FILTER

See the following page for models with -WF1 Water Filter (A172-FG-VR-WF1)

FILTER CARTRIDGE REPLACEMENT:

1. Remove access panel, this allows access to the filter and the water inlet valve (provided by others). Turn valve knob 1/4 turn clockwise to close.
2. Slowly lift water filter from the water filter bracket assembly.
3. With the water filter removed from the bracket assembly, hold the cap firmly. Turn the replaceable cartridge filter counterclockwise to remove.
4. Remove and replace the cartridge turning clockwise to secure.
5. Re-insert the water filter into the water filter bracket assembly.
6. Turn water inlet 1/4 turn knob 1/4 turn counterclockwise to open and test for leaks and proper operation before closing access panel.

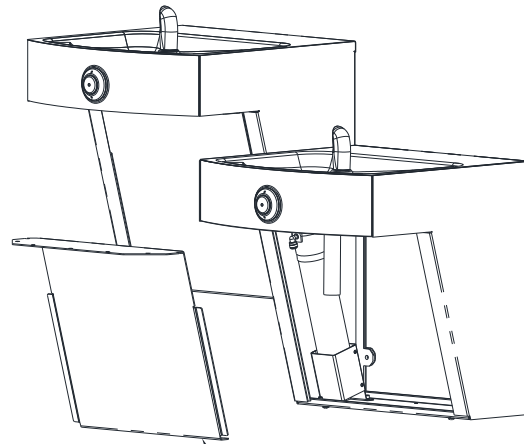

ACCESS PANEL

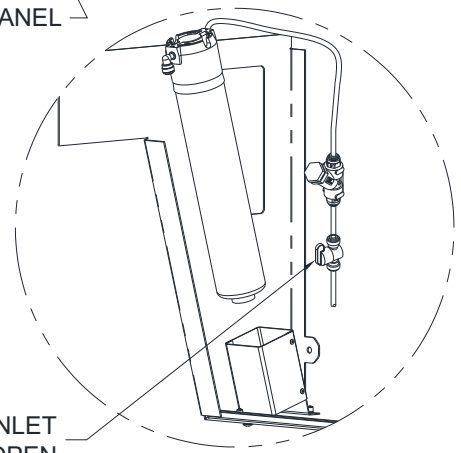

WATER INLET VALVE OPEN

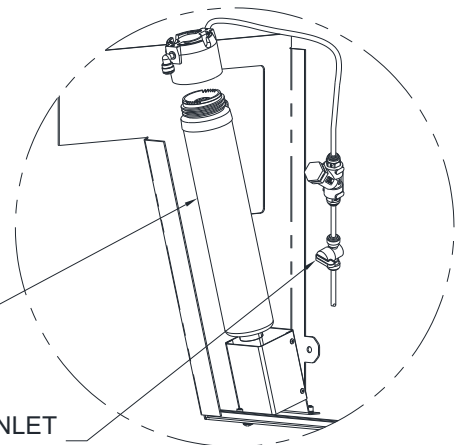

REPLACEMENT CARTRIDGE

WATER INLET VALVE CLOSED



WATER COOLERS

INSTALLATION/MAINTENANCE INSTRUCTIONS

PUSH-IN FITTING INSTALLATION

NOTE: FITTINGS AND TUBE SHOULD BE KEPT CLEAN, BAGGED AND UNDAMAGED PRIOR TO INSTALLATION.

TO CUT TUBE:

Cut to fit length of 1/4" PE tubing and remove any burrs or sharp edges. Ensure that the outside diameter is free from score marks. Tube ends should be square.

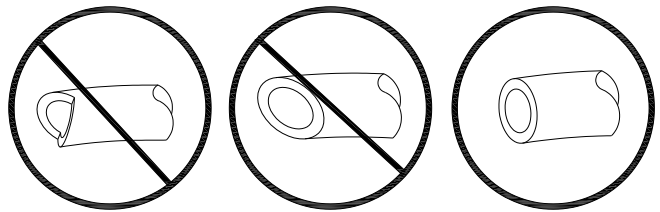

INSERTING THE TUBE:

1. Firmly and fully insert the tubing end into the push-in fitting up to the tube stop located approximately 1/2" deep.

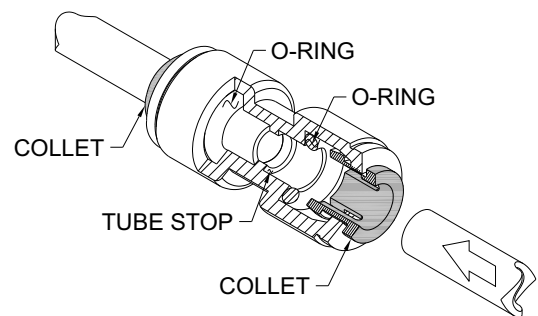

2. Pull on the fitted tubing to ensure it is secure. Tube should not come free from the fitting. Water test the connection assembly prior to leaving the site to ensure there are no leaks.

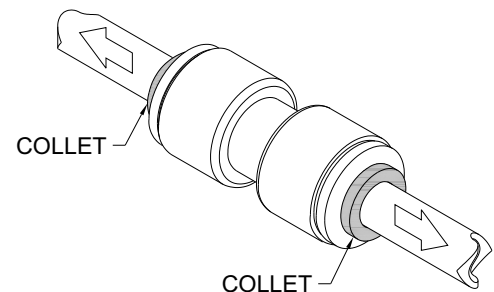

DISCONNECTING THE TUBE:

To disconnect the tube from the fitting ensure that the water line is depressurized. Push collet square towards the push-in fitting body and hold. While holding the collet in, pull on the PE tubing to remove from the push-in fitting.

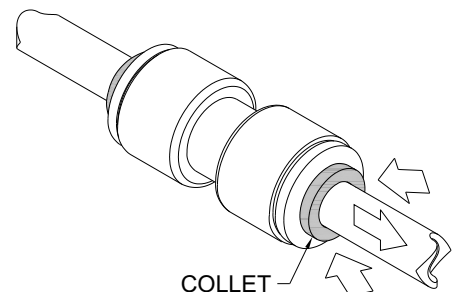



WATER COOLERS

INSTALLATION/MAINTENANCE INSTRUCTIONS

COOLER PARTS BREAKDOWN

Murdock Manufacturing
Part #: 7003-194-199
Ph: 800-743-8259

(32)

Universal Maintenance Tool

- Button Removal
- Cartridge Retaining Nut
- Strainer Plug
- Removal of P.E. Tubing from Push-in Fittings

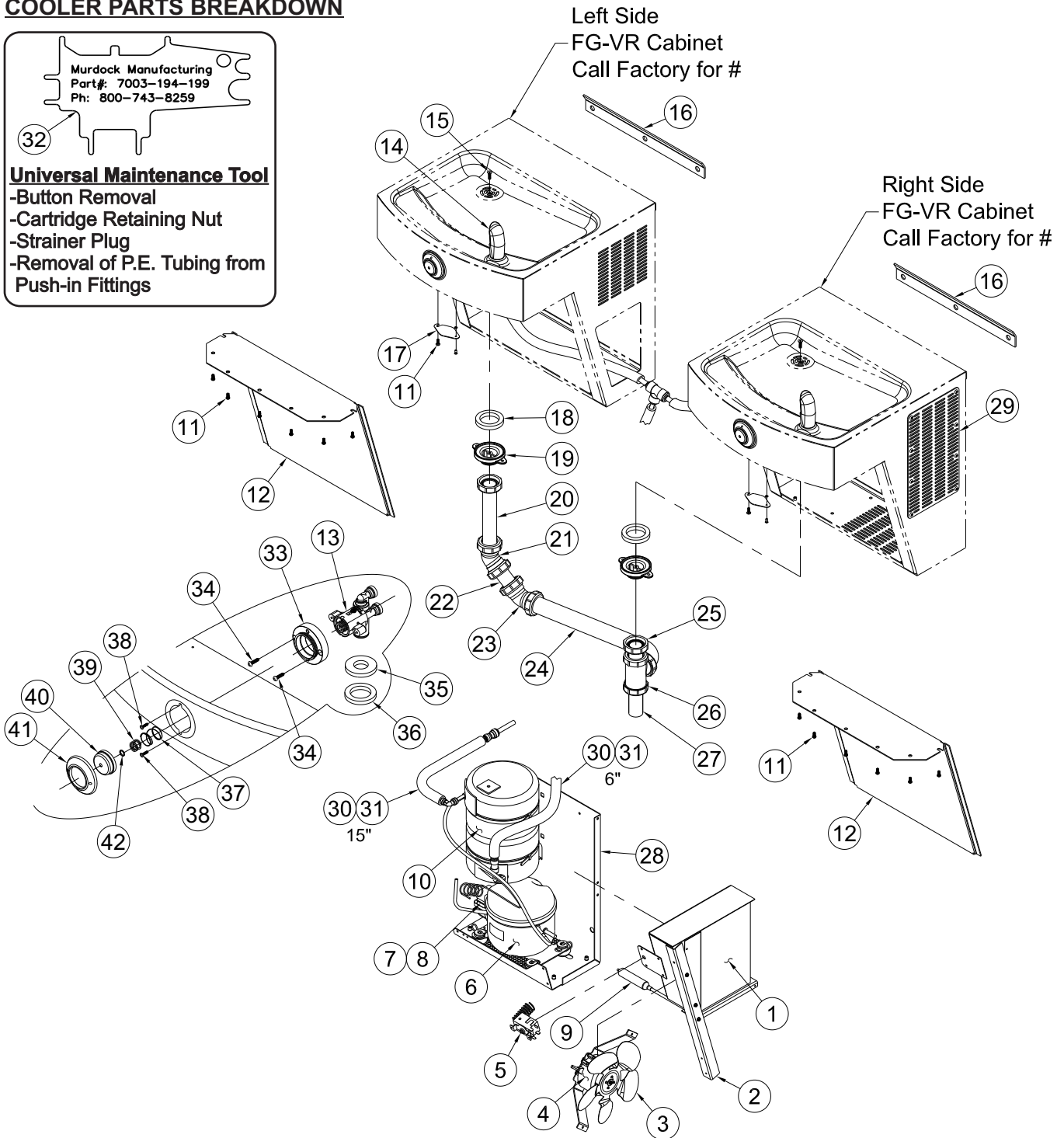

Standard A171.8 series refrigerated ADA cooler shown. All 1/4" O.D. Plastic tubing (30) must be insulated with (31) foam insulation.

NOTE: See next page for table of part numbers corresponding to drawing above.



WATER COOLERS

INSTALLATION/MAINTENANCE INSTRUCTIONS

COOLER PARTS BREAKDOWN TABLE

NOTE: See previous page for fixture drawing corresponding to table of parts below.

ITEM #	PART NUMBER	DESCRIPTION
1	7003-201-000	CONDENSER
2	7003-634-199	FG-VR SUPPORT STRUT
3	7003-355-000	FAN BLADE
4	7003-302-001	FAN MOTOR
	7012-062-000	FAN MOTOR - 220V
5	7003-250-000	COLD CONTROL
6	7012-801-000	COMPRESSOR
	7012-030-001	COMPRESSOR - 220V
7	7012-802-000	START RELAY
	7012-031-000	START RELAY - 220
8	7012-803-000	START CAPACITOR
	7012-032-000	START CAPACITOR - 220
9	7012-050-000	FILTER / DRYER
10	7003-115-001	EVAPORATOR ASSEMBLY
11	0112-002-000	CENTER REJECT ALLEN BUTTON HEAD SCREW
12	7003-681-199	FG-VR STAINLESS STEEL KNEE PANEL
13	7003-095-001	VALVE ASSEMBLY
14	7000-012-001	STAINLESS STEEL BUBBLER ASSEMBLY
15	0152-006-000	CENTER REJECT ALLEN FLAT HEAD SCREW
16	7012-803-000	FG-VR HANGER BRACKET
17	7003-681-299	ACCESS PLATE, -VR AUTO-STOP
18	7000-006-000	FLAT DRAIN ADAPTER GASKET
19	7000-005-199	DRAIN ADAPTER
20	7000-019-001	WASTE TAILPIECE ASSEMBLY
21	7003-073-000	1-1/4" x 1-1/2" COMPRESSION 45° ELBOW
22	1758-043-299	1-1/2" O.D. x 3" LONG DRAIN TUBE
23	7003-072-000	1-1/2" x 1-1/2" COMPRESSION 45° ELBOW
24	1758-043-199	1-1/2" O.D. x 15" LONG WASTE ARM
25	7000-032-001	1-1/4" x 1-3/4" LONG DRAIN TUBE ASSEMBLY
26	7003-070-000	1-1/2" COMPRESSION TEE
27	7000-032-299	1-1/4" O.D. BRASS WASTE TAILPIECE
28	7003-300-005	BACK PANEL ASSEMBLY
29	7003-604-002	ACCESS PANEL
30	2169-000-000	1/4" O.D. TUBING
31	7012-055-000	TUBE INSULATION
32	7003-194-199	(-VR) MAINTENANCE TOOL
33	7003-198-199	(-VR) PUSHBUTTON MOUNTING SLEEVE
34	0124-055-000	#8x3/4 PHILLIPS ROUND HEAD SS SM SCREW
35	7003-199-000	AUTO-STOP CONDENSATION GASKET, UPPER
36	7003-200-000	AUTO-STOP CONDENSATION GASKET, LOWER
37	7003-193-000	(-VR) PUSHBUTTON RETURN SPRING
38	0161-062-000	#6-32 x 1/2" S/S PHIL FLAT HD SCREW
39	7003-195-000	(-VR) PUSHBUTTON OVERTRAVEL SPRING
40	7003-196-199	(-VR) PUSHBUTTON, CHROME
41	7003-197-199	(-VR) PUSHBUTTON ESCUTCHEON, CHROME
42	7003-192-199	(-VR) PUSHBUTTON SPRING SPACER

Repairs must be made with Acorn Engineering parts only. Please order through your local representative or distributor. The phone number to locate your local representative is 1.800.591.9360.